



MET ONE 6000P SERIES REMOTE AIRBORNE PARTICLE COUNTERS

0.5 AND 5 MICRON COUNTER WITH BUILT-IN VACUUM PUMP



CHARACTERIZED
by ingenuity.



THE MET ONE 6000P 0.5 μm SENSOR REMOTE AIRBORNE PARTICLE COUNTER IS THE MOST RELIABLE TOP PERFORMING, HIGH SENSITIVITY REMOTE PARTICLE COUNTER WITH A BUILT-IN PUMP.

High performance

0.5 μm sensitivity counter designed for ISO 21501 compliance for data accuracy and reliability.

Easy to integrate with any FMS system

Communication options of serial, (RS232 or RS485), Ethernet only or Ethernet and Analog in dual communication mode (send data to two different locations at once).

Faster troubleshooting and reduced downtime

Instrument can be diagnosed for flow, sensor, communication failures, and count alarm or count alert through built-in or external light stack.

Long Life Laser™ diode

Reduces the need for replacement parts and the overall cost of ownership.

Built-in DP sensor controlled vacuum pump

Reduces initial installation cost and system infrastructure complexity. Install wherever you want without having to worry about access to an extensive vacuum system.

Built-in flow sensor

Improves operational reliability during continuous monitoring.



With an array of industry leading features and simplified installation options, the MET ONE 6000P is easy to integrate with any facility monitoring system.

- 1 AC power input
- 2 Fuse Holder
- 3 Exhaust fitting
- 4 Calibration port (Service use only)
- 5 Serial communication connector; DC power input (DC version)
- 6 Relative Humidity (RH) and temperature sensor port
- 7 Service port and optional light stack port
- 8 4-20 mA analog output; DC power input (DC version)
- 9 Ethernet Rj45 connector
- 10 DC power input (DC version)

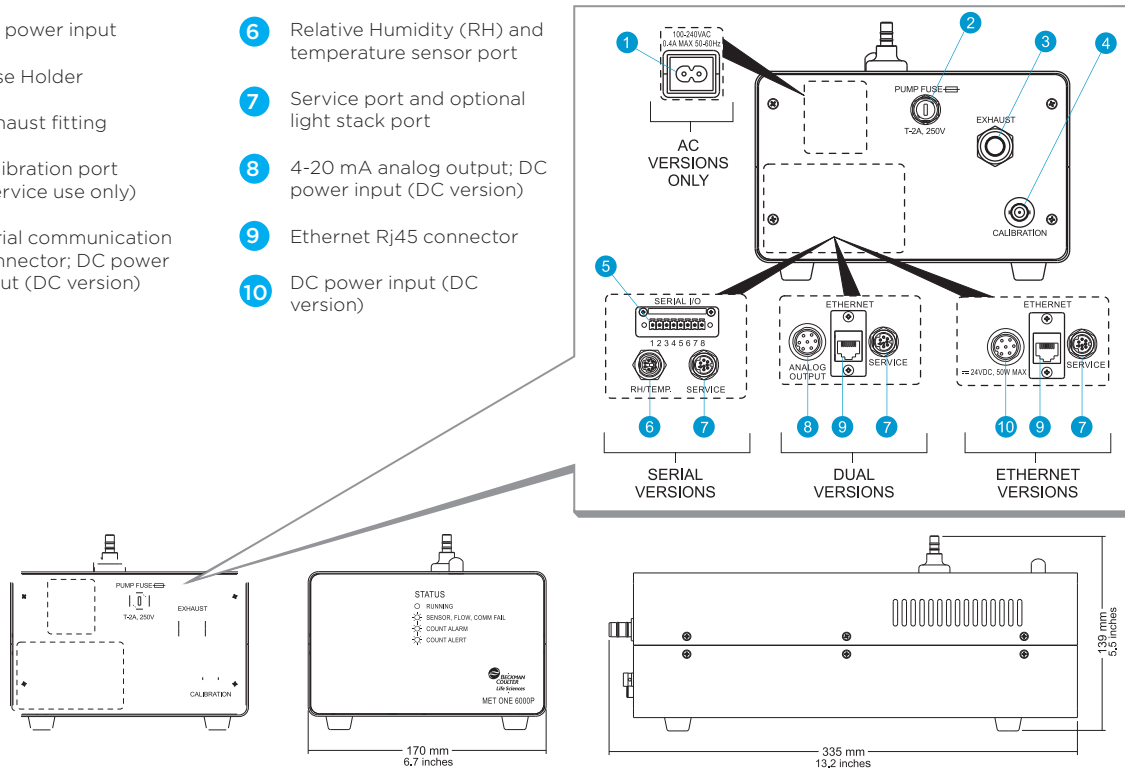

The MET ONE 6000P series remote airborne particle counter offers accurate and reliable continuous particle monitoring. With a sensitivity range of 0.5 to 10 μm , the MET ONE 6000P series is designed to meet the specific needs of cleanroom operations within the pharmaceutical, semiconductor, hard disk drive and flat panel display industries.

With an array of industry leading features and simplified installation options, the MET ONE 6000P is easy to integrate with any facility monitoring system. These features also reduce downtime for instrument removal and reinstallation during routine calibration and preventative maintenance cycles. Built with Long Life Laser™ technology, the MET ONE 6000P offers enhanced diagnostic features that reduce troubleshooting time and related downtime costs.

New model for 2013 – 6015P with Serial communication (RS232-RS485) and integrated relative humidity and temperature port. This port enables the use of an optional probe that includes RH/ Temp data along with the particle count data stream to further simplify installation and increase the information your monitoring system provides.



Specifications

Light Source	Long Life Laser™ diode
Weight	4.62 k g (10.2 lb)
Dimensions	17.15 x 11.43 x 31.75 cm (6.75 x 4.5 x 12.5 inches)
Enclosure	316L Stainless Steel
Status Indicator	Multicolored LED for normal status, count alarm, count alert, sensor failure, flow failure or communication failure
Power Requirements	24 VDC ± 10% or 100 to 230 VAC 50/60 Hz (source: Class 2 limited energy, <150 VAC)
Power Consumption	50 W DC, 7.9 W AC maximum
Operating Temperature	10 to 32 °C (50 to 90 °F), 5 to 95% relative humidity, non-condensing
Storage Temperature	-40 to 70 °C (-40 to 158 °F), 5 to 98% relative humidity, non-condensing
Signal Output Options	Analog 4–20mA Ethernet with TCP/IP protocol Pulse Serial RS-232 Serial RS-485 with Modbus RTU or FXB communications protocol
Pump Type	Air Vacuum, rated for continuous use
Number of Size Channels	Standard 2 or Optional 4
Flow Control	Micro processor with Differential Pressure sensor
Coincidence Loss	All communication options except Pulse: 10% at 20,000,000 particles/m ³ (566,000/ft ³)
False Count Rate	One or less in five minutes
Accessories Included	Isokinetic Probe, Purge Filter, Configuration Kit, Operator Manual
How To Order	2088615-PF-EA Ethernet only, AC Power 2088615-PF-ED Ethernet only, DC Power 2088615-PF-DA Dual (Ethernet & 4-20 mA), AC Power 2088615-PF-DD Dual (Ethernet & 4-20 mA), DC Power 2088615-PF-SA (Serial only), AC power 2088615-PF-SD (Serial only), DC power



WANT TO LEARN MORE?

 <https://aquaanalytic.com.ua/>

 +38 057 725 95 01

 info@aquaanalytic.com.ua